

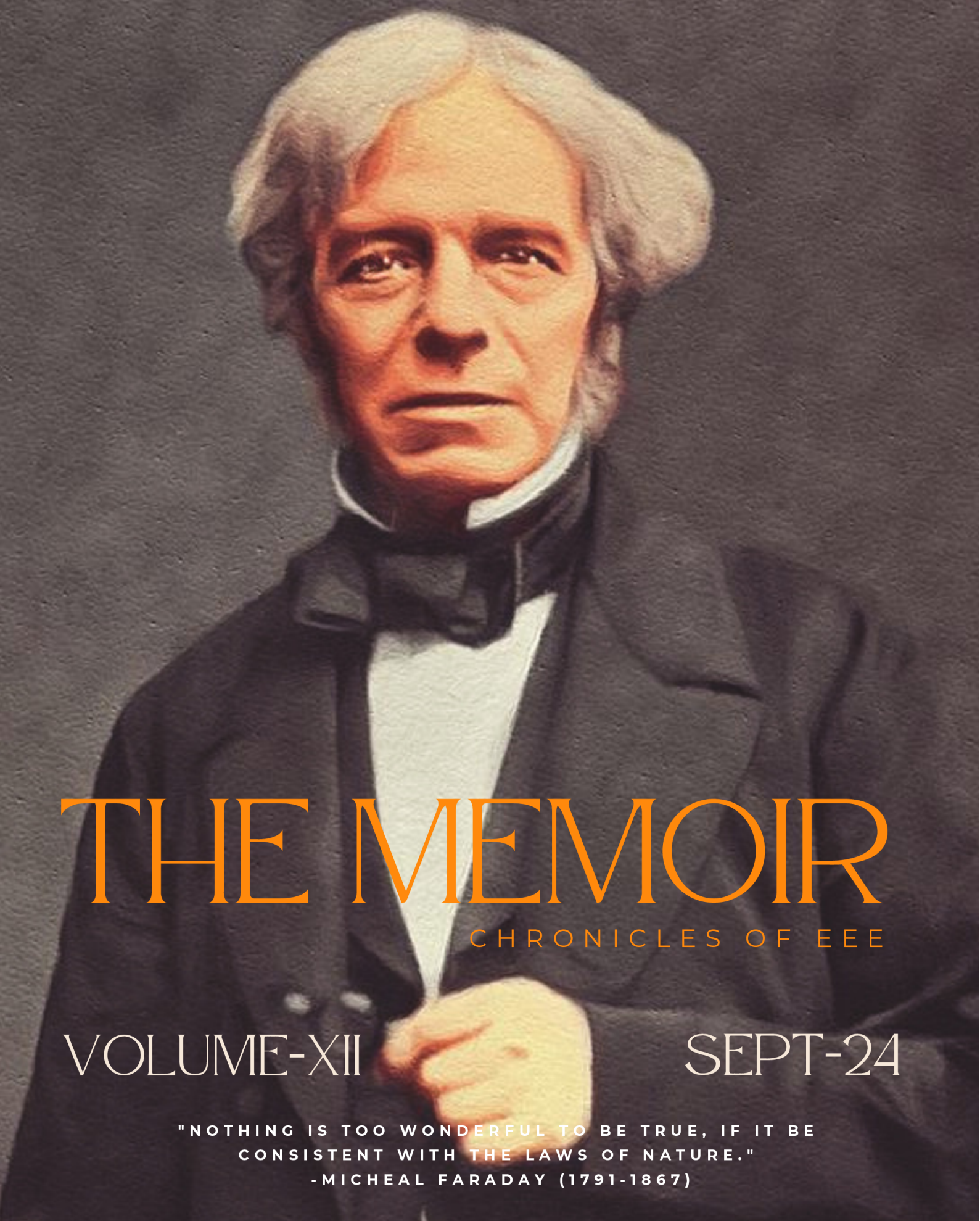

DEPARTMENT OF ELECTRICAL AND ELECTRONICS ENGINEERING
COLLEGE OF ENGINEERING VIZIANAGARAM(A)
JAWAHARLAL NEHRU TECHNOLOGICAL UNIVERSITY GURAJADA
VIZIANAGARAM



CLIQUE



THE MEMOIR

CHRONICLES OF EEE

VOLUME-XII

SEPT-24

"NOTHING IS TOO WONDERFUL TO BE TRUE, IF IT BE
CONSISTENT WITH THE LAWS OF NATURE."

-MICHEAL FARADAY (1791-1867)

INVENTIONS OF MICHEAL FARADAY

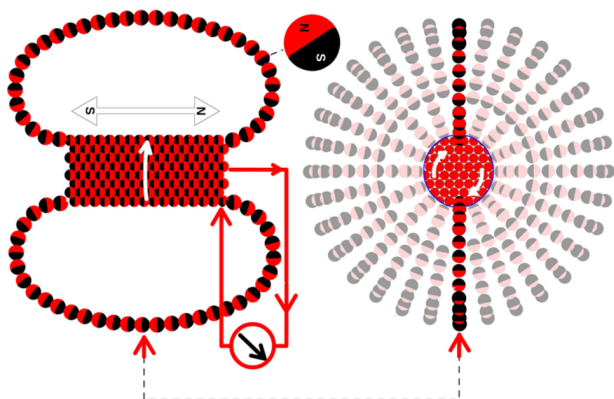

Faraday's Paradox

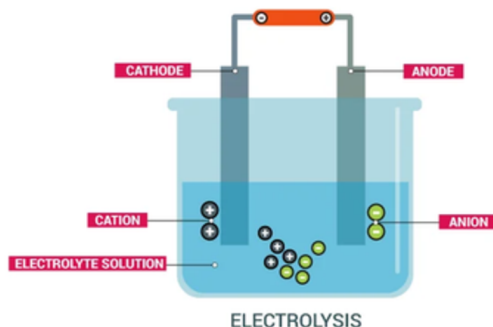

Faraday's Electrolysis

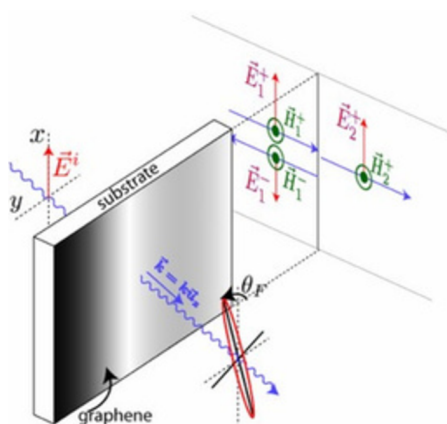

Faraday's Wave

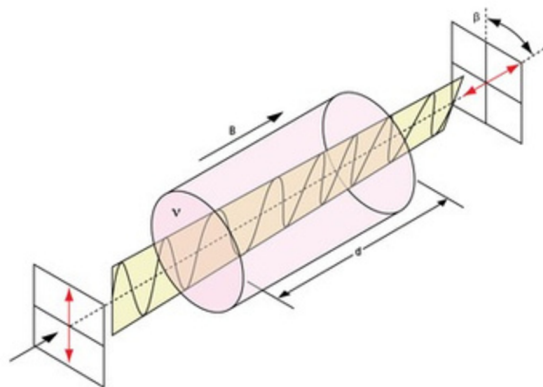

Faraday's Rotator

Faraday's Constant

Value, Formula, Application, Calculation

$$F = N_A \cdot e$$

$$F = 96485.33289(59) \text{ C mol}^{-1}$$

$$F = 96\,485.3329 \text{ s A / mol}$$

$$F = 23.061 \text{ kcal per volt gram equivalent}$$

$$F = 26.801 \text{ A}\cdot\text{h/mol}$$

Faraday's Constant

EDITORIAL COLUMN

Dear Readers,

We, the department of Electrical and Electronics Engineering of JNTU-GV, are proud to present you the 12th edition of our magazine "**THE MEMOIR- CHRONICLES OF EEE**" as a tribute to MICHAEL FARADAY.

We would like to express our heartfelt gratitude to the Principal(i/c), **DR. R. RAJESWARA RAO**, for his generous support in ensuring that students receive a meaningful learning experience. Our thanks also go to the Head of the Department, **Dr. V.S. VAKULA**, whose continuous guidance has created a stimulating and productive environment. We appreciate Assistant Professor of EEE and Convenor, **Dr. A. PADMAJA**, for her unwavering encouragement in every possible way. we extend our thanks to the faculty coordinators **SRI. P. SREENIVASULA REDDY** Asst professor(C) of EEE and **SMT. T. SIRISHA** Asst professor(C) of EEE, all the faculty members Electrical and Electronics Engineering department and our fellow students for their steadfast support in shaping this magazine into a remarkable publication.

A college magazine is designed to foster creativity among students and serve as a platform to highlight their exceptional artistic talents. With this goal in mind, we have endeavored to include a wide array of creative contributions from students. This edition features insightful articles on topics such as a renowned scientist, Hyper loop, Three Gorges Dam, A brief history of automation of electricity generation, Wireless Power Theft Monitoring, Semiconductor Chips, Neura link, How do all all-electric cars work, Electric Vehicles and Chandrayan 3. We have also included general topics like current affairs and inspiring stories to enrich the content.

We want to extend our heartfelt gratitude to all the authors for their passion and creativity, which truly shines through as you browse the pages. We hope you enjoy the experience, and please don't hesitate to share your feedback with us. We truly value your comments and suggestions. Happy reading!

THANK YOU
Team Magazine

CONTENTS

S.NO.	NAME OF THE ARTICLE	PAGE
1.	PRINCIPAL MESSAGE	04
2.	HOD'S MESSAGE	05
3.	MOTTO OF THE MAGAZINE	06
4.	MICHEAL FARADAY	07
5.	SCIENTISTS	09
6.	ARTICLE ABOUT NICOLAS TESLA	11
7.	HYPER LOOP	13
8	THREE GORGES DAM	15
9.	A BRIEF HISTORY OF AUTOMATION OF ELECTRICITY GENERATION	17
10.	WIRELESS POWER THEFT MONITORING	19
11.	SEMICONDUCTOR CHIPS	21
12.	NEURALINK	23
13.	HOW DO ALL-ELECTRIC CARS WORK?	25
14.	ELECTRIC VEHICLES	27
15.	CHANDRAYAAN 3	29
16.	STUDENT ACTIVITIES	31
17.	LITERARY NODE	36

Designed and Edited by:

KAPPALA ADARSH- 22VV1A0225
TEJA DURGA SURAJ G- 22VV1A0259
III B.TECH EEE

PRINCIPAL'S MESSAGE:



I am delighted to see the 12th edition of 'THE MEMOIR' magazine, meticulously prepared by our talented Electrical and Electronics Engineering (EEE) students, on the occasion of Michael Faraday's birth anniversary celebrations.

As we move forward in this rapidly changing world, it is imperative that we recognize the crucial role that EEE students will play in shaping our future.

I applaud our students for their efforts in curating articles, interviews, and features that underscore the significance of Michael Faraday's contributions to the field of electromagnetism and the impact of his legacy on modern technology.

As we celebrate Faraday's birth anniversary, we are reminded that the future of our planet depends on our ability to harness renewable resources, reduce carbon footprints, and develop sustainable solutions. EEE students have a vital role to play in this endeavor, and I encourage you to continue exploring, innovating, and pushing the boundaries of what is possible.

By
DR. R. RAJESWARA RAO
PRINCIPAL(i/c)
JNTUGV - CEV(A)

H O D ' S M E S S A G E :



I am excited that the students at the Department of Electrical and Electronics Engineering, College of Engineering (A), JNTUGV have published "The MEMOIR" - VOLUME XII of their yearly newsletter.

The MEMOIR has become an integral part of your department's legacy, reflecting the talents, innovations, and accomplishments of your student community.

Your tireless efforts in crafting both the technical and artistic sections of the magazine have truly paid off. The publication showcases your creativity, technical expertise, and dedication to sharing knowledge and experiences.

I wish them all the success and congratulate for all the effort they put into writing the technical and artistic sections of the magazine, I would like to express my gratitude.

I commend the editors for their perseverance in making this magazine, year after year. Your commitment to preserving the department's memories and stories is truly commendable.

I believe it is fantastic that the editors have continued towards making the magazine a reality.

By
DR. V. S. VAKULA
ASST. PROFESSOR &
HEAD OF DEPT EEE
JNTUGV-CEV(A)

MOTTO OF THE MAGAZINE

Empowered by the spark of curiosity, driven by the passion for discovery, and guided by the genius of Michael Faraday, we ignite the flame of innovation. Our mission is to illuminate the path of scientific inquiry, explore the frontiers of electromagnetism, and inspire the next generation of visionaries. Through the pages of this magazine, we celebrate Faraday's enduring legacy, unravel the secrets of his groundbreaking inventions, and showcase the transformative power of science and technology.

From Faraday's revolutionary experiments with electricity to the modern-day advancements in quantum mechanics, we explore the remarkable progress made in the field of electromagnetism. Discover the intricate workings of electromagnetic waves, the groundbreaking applications of magnetic fields, and the limitless potential of renewable energy sources.

But our mission goes beyond just presenting scientific concepts. We believe in nurturing the next generation of innovators and thinkers. Within these pages, you will find stories of young scientists pushing the boundaries of what is possible, experiments that can be conducted in your own backyard, and opportunities to get involved in the scientific community.

As we embark on this electrifying journey, this magazine is to ignite your curiosity, fuel your passion for discovery, and to inspire you to become a visionary in the world of science and technology. The contribution made illuminate the path of scientific inquiry and shape a brighter future for all.

MICHAEL FARADAY

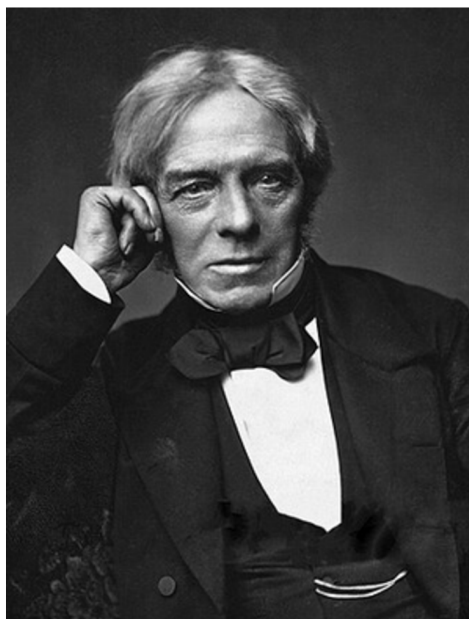

Michael Faraday(22 September 1791 - 25 August 1867) was an English scientist who contributed to the study of electromagnetism and electrochemistry. His main discoveries include the principles underlying electromagnetic induction, diamagnetism and electrolysis. Although Faraday received little formal education, as a self-made man, he was one of the most influential scientists in history.[1] It was by his research on the magnetic field around a conductor carrying a direct current that Faraday established the concept of the electromagnetic field in physics. Faraday also established that magnetism could affect rays of light and that there was an underlying relationship between the two phenomena.[2][3] He similarly discovered the principles of electromagnetic induction, diamagnetism, and the laws of electrolysis. His inventions of electromagnetic rotary devices formed the foundation of electric motor technology, and it was largely due to his efforts that electricity became practical for use in technology.[4]

As a chemist, Faraday discovered benzene, investigated the clathrate hydrate of chlorine, invented an early form of the Bunsen burner and the system of oxidation numbers, and popularised terminology such as "anode", "cathode", "electrode" and "ion". Faraday ultimately became the first and foremost Fullerian Professor of Chemistry at the Royal Institution, a lifetime position.

Faraday was an experimentalist who conveyed his ideas in clear and simple language. His mathematical abilities did not extend as far as trigonometry and were limited to the simplest algebra. James Clerk Maxwell took the work of Faraday and others and summarised it in a set of equations which is accepted as the basis of all modern theories of electromagnetic phenomena. On Faraday's uses of lines of force, Maxwell wrote that they show Faraday "to have been in reality a mathematician of a very high order - one from whom the mathematicians of the future may derive valuable and fertile methods." [5] The SI unit of capacitance is named in his honour: the farad.

Albert Einstein kept a picture of Faraday on his study wall, alongside pictures of Isaac Newton and James Clerk Maxwell. [6] Physicist Ernest Rutherford stated, "When we consider the magnitude and extent of his discoveries and their influence on the progress of science and of industry, there is no honour too great to pay to the memory of Faraday, one of the greatest scientific discoverers of all time."

SOURCE:

https://en.wikipedia.org/wiki/Nikola_Tesla

SCIENTISTS



Carl Wilhelm Siemens
(1823-1883)



Charles-Augustin de Coulomb
(1736-1806)

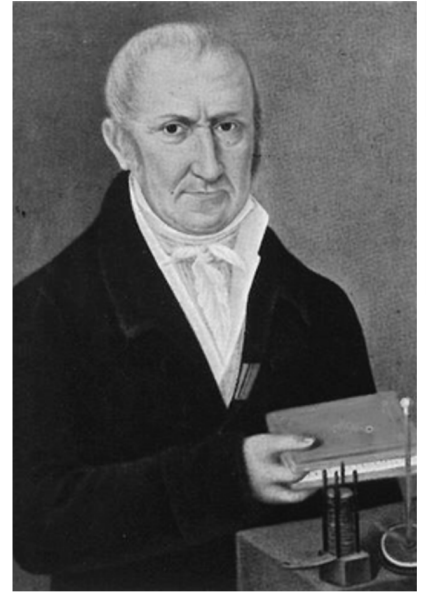

Alessandro Volta
(1745-1827)



Andre Marie Ampere
(1775-1836)



Edward Lawry Norton
(1898-1983)

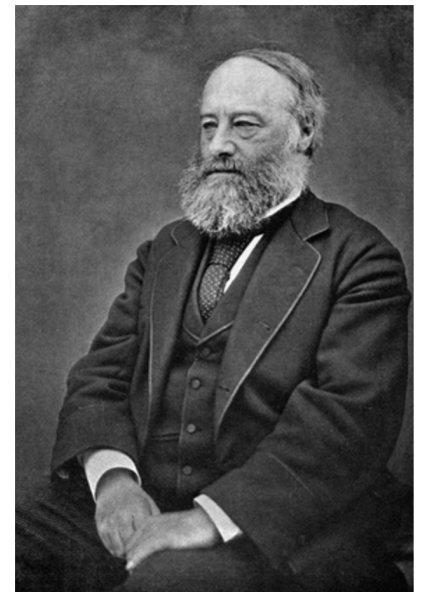

James Prescott Joule
(1818-1889)

SCIENTISTS

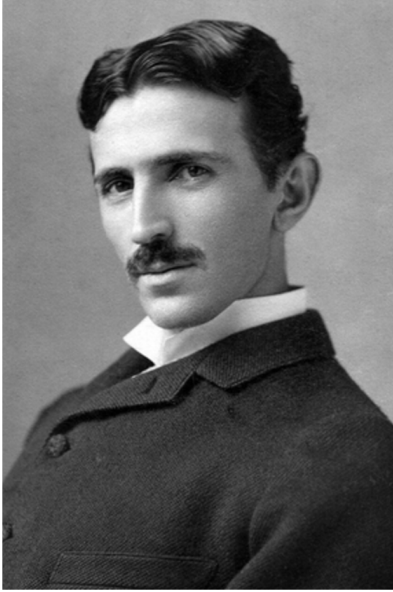

Nikola Tesla
(1856-1943)



Joseph Henry
(1797-1878)



Wilhelm Eduard Weber
(1804-1894)

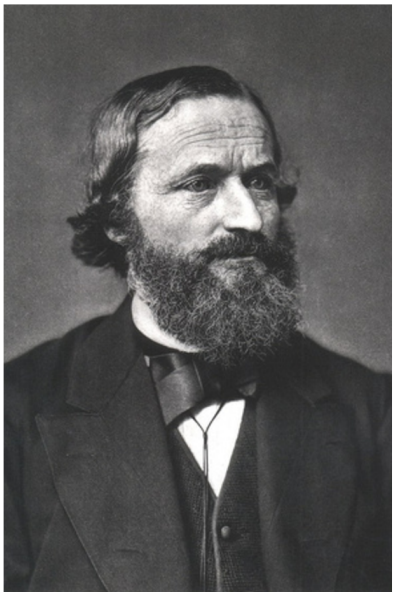

Gustav Robert Kirchhoff
(1824-1887)



Georg Simon Ohm
(1789-1854)



Guglielmo Giovanni
(1874-1937)

ARTICLE ABOUT A NIKOLA TESLA

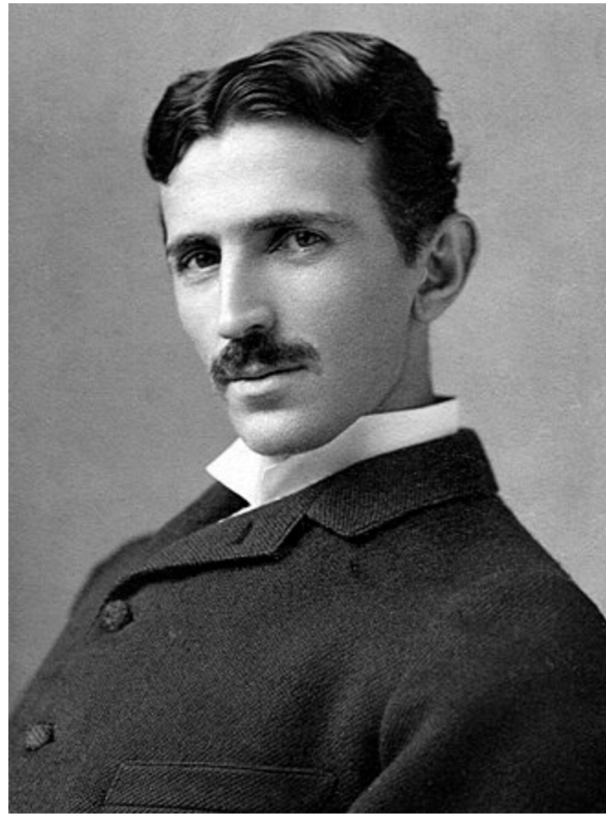

NIKOLA TESLA

Nikola Tesla : (10 July 1856– 7 January 1943) was a Serbian–American engineer, futurist, and inventor. He is known for his contributions to the design of the modern alternating current (AC) electricity supply system. Born and raised in the Austrian Empire, Tesla first studied engineering and physics in the 1870s without receiving a degree. He then gained practical experience in the early 1880s working in telephony and at Continental Edison in the new electric power industry. In 1884 he immigrated to the United States, where he became a naturalized citizen. He worked for a short time at the Edison Machine Works in New York City before he struck out on his own. With the help of partners to finance and market his ideas, Tesla set up laboratories and companies in New York to develop a range of electrical and mechanical devices.

His AC induction motor and related polyphase AC patents, licensed by Westinghouse Electric in 1888, earned him a considerable amount of money and became the cornerstone of the polyphase system which that company eventually marketed.

Attempting to develop inventions he could patent and market, Tesla conducted a range of experiments with mechanical oscillators/generators, electrical discharge tubes, and early X-ray imaging. He also built a wirelessly controlled boat, one of the first ever exhibited. Tesla became well known as an inventor and demonstrated his achievements to celebrities and wealthy patrons at his lab, and was noted for his showmanship at public lectures. Throughout the 1890s, Tesla pursued his ideas for wireless lighting and worldwide wireless electric power distribution in his high-voltage, high-frequency power experiments in New York and Colorado Springs. In 1893, he made pronouncements on the possibility of wireless communication with his devices. Tesla tried to put these ideas to practical use in his unfinished Wardencllyffe Tower project, an intercontinental wireless communication and power transmitter, but ran out of funding before he could complete it.

After Wardencllyffe, Tesla experimented with a series of inventions in the 1910s and 1920s with varying degrees of success. Having spent most of his money, Tesla lived in a series of New York hotels, leaving behind unpaid bills. He died in New York City in January 1943.

Tesla's work fell into relative obscurity following his death, until 1960, when the General Conference on Weights and Measures named the International System of Units (SI) measurement of magnetic flux density the tesla in his honor. There has been a resurgence in popular interest in Tesla since the 1990s.

SOURCE:

https://en.wikipedia.org/wiki/Nikola_Tesla

TEJA DURGA SURAJ G
22VV1A0259
III B.TECH EEE

H Y P E R L O O P

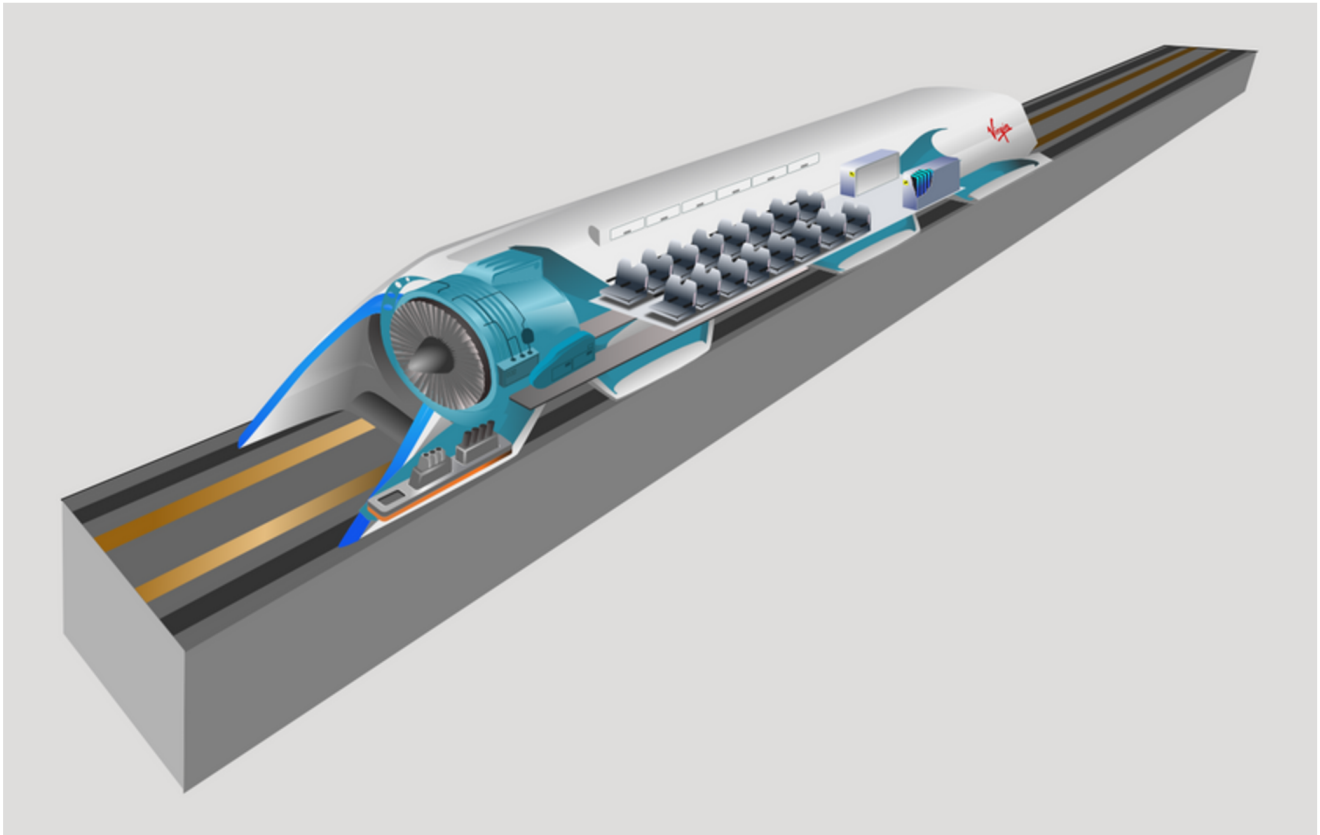

Hyperloop is a proposed high-speed transportation system for both passengers and freight. The concept was published by Elon Musk in a 2013 white paper, where the hyperloop was described as a transportation system using capsules supported by an air-bearing surface within a low-pressure tube.

Hyperloop systems have three essential elements: tubes, pods, and terminals. The tube is a large, sealed low-pressure system (typically a long tunnel). The pod is a coach at atmospheric pressure that experiences low air resistance or friction inside the tube using magnetic propulsion (in the initial design, augmented by a ducted fan). The terminal handles pod arrivals and departures.

The hyperloop, in the form proposed by Musk, differs from traditional vactrains by relying on residual air pressure inside the tube to provide lift from aerofoils and propulsion by fans; however, many subsequent variants using the name "hyperloop" have remained relatively close to the core principles of vactrains.

Concept art of hyperloop inner workings

Hyperloop was teased by Elon Musk at a 2012 speaking event, and described as a "fifth mode of transport".[4] Musk released details of an alpha-version in a white paper on 22 August 2013, in which the hyperloop design incorporated reduced-pressure tubes with pressurized capsules riding on air bearings driven by linear induction motors and axial compressors.[5] The white paper showed an example hyperloop route running from the Los Angeles region to the San Francisco Bay Area, roughly following the Interstate 5 corridor. Some transportation analysts challenged the cost estimates in the white paper, with some predicting that a hyperloop would run several billion dollars higher.

The hyperloop concept has been promoted by Musk and SpaceX, and other companies or organizations were encouraged to collaborate in developing the technology. A Technical University of Munich hyperloop set a speed record of 463 km/h (288 mph) in July 2019 at the pod design competition hosted by SpaceX in Hawthorne, California. Virgin Hyperloop conducted the first human trial in November 2020 at its test site in Las Vegas, reaching a top speed of 172 km/h (107 mph). Swisspod Technologies unveiled a 1:12 scale testing facility in a circular shape to simulate an "infinite" hyperloop trajectory in July 2021 on the EPFL campus at Lausanne, Switzerland. In 2023, a new European effort to standardize "hyperloop systems" released a draft standard.

Hyperloop One, one of the best well-known and well-funded players in the hyperloop space, declared bankruptcy and ceased operations on 31 December 2023. Other companies continue to pursue hyperloop technology development.

SOURCE:

<https://en.m.wikipedia.org/wiki/Hyperloop>

G. NIKHITHA
23VV5A0272
III B.TECH EEE

THREE GORGES DAM



The Three Gorges Dam is a hydroelectric gravity dam that spans the Yangtze River near Sandouping in Yiling District, Yichang, Hubei province, central China, downstream of the Three Gorges. The world's largest power station in terms of installed capacity (22,500 MW), the Three Gorges Dam generates 95 ± 20 TWh of electricity per year on average, depending on the amount of precipitation in the river basin. After the extensive monsoon rainfalls of 2020, the dam's annual production reached nearly 112 TWh, breaking the previous world record of ~ 103 TWh set by Itaipu Dam in 2016.

In addition to generating electricity, the dam was designed to increase the Yangtze River's shipping capacity. By providing flood storage space, the dam reduces the potential for flooding downstream, which historically plagued the Yangtze Plain. In 1931, floods on the river caused the deaths of up to 4 million people. As a result, China regards the project as a monumental social and economical success, with the design of state-of-the-art large turbines and a move toward limiting greenhouse gas emissions. However, the dam has led to some ecological changes, including an increased risk of landslides, which have made it controversial domestically and abroad.

The dam's body was completed in 2006; the power plant was completed and fully operational by 2012, when the last of the main water turbines in the underground plant began production. Each of the main water turbines has a capacity of 700 MW. Combining the capacity of the dam's 32 main turbines with the two smaller generators (50 MW each) that provide power to the plant itself, the total electric generating capacity of the Three Gorges Dam is 22,500 MW. The last major component of the project, the ship lift, was completed in 2015.

HISTORY:

Sun Yat-sen envisioned a large dam across the Yangtze River in *The International Development of China* (1919). He wrote that a dam capable of generating 30 million horsepower (22 GW) was possible downstream of the Three Gorges. In 1932, the Nationalist government, led by Chiang Kai-shek, began preliminary work on plans in the Three Gorges. In 1939, during the Second Sino-Japanese War, Japanese military forces occupied Yichang and surveyed the area.

In 1944, the United States Bureau of Reclamation's head design engineer, John L. Savage, surveyed the area and drew up a dam proposal for a "Yangtze River Project". Some 54 Chinese engineers went to the US for training. The original plans called for the dam to employ a unique method for moving ships: the ships would enter locks at the dam's lower and upper ends and then cranes would move them from each lock to the next. Groups of craft would be lifted together for efficiency.

After the 1949 Communist Revolution, Mao Zedong supported the project, but began the Gezhouba Dam project nearby first, and economic problems including the Great Leap Forward and the Cultural Revolution slowed progress. After the 1954 Yangtze River Floods, in 1956, Mao wrote "Swimming", a poem about his fascination with a dam on the Yangtze River. In 1958, after the Hundred Flowers Campaign, some engineers who spoke out against the project were imprisoned.

SOURCES:

https://en.wikipedia.org/wiki/Three_Gorges_Dam

K. ADARSH
22VV1A0225
III B.TECH EEE

A BRIEF HISTORY OF AUTOMATION OF ELECTRICITY GENERATION



The automation of power generation has gone through a long journey and yet has miles to go to build cybersecurity in smart grids and smart metering besides integrating renewables. A look back from the early days of automation till date may not be out of place here.

Mechanical Controls:

Mechanical controls in electricity generation refer to early automation systems that utilized mechanical devices to regulate and control various aspects of power plant operations. Key components of these systems included:

Governors: Mechanical governors were used to control the speed of steam turbines and maintain a consistent rotational speed, crucial for stable electricity generation. They adjusted the flow of steam to the turbine based on load changes, ensuring the generator's output frequency remained constant.

Relays and Switches:

These devices were used to protect equipment and ensure safe operation. For instance, mechanical relays could disconnect a generator from the grid if certain parameters (such as voltage or current) exceeded safe limits.

Valve Actuators:

Mechanical actuators controlled the opening and closing of valves in various systems, such as steam or water flow in turbines and boilers. This control was essential for regulating power output and maintaining efficiency.

Pressure and Temperature Regulators:

These devices managed the pressure and temperature levels within boilers and turbines, ensuring optimal operating conditions and preventing damage.

Flyball Governors:

Specifically used in steam engines, flyball governors were among the earliest mechanical control systems. They used centrifugal force to adjust the steam valve, regulating engine speed based on load changes. Mechanical control systems in power generation, prevalent before the advent of electronic and digital controls, faced several key challenges:

Limited Precision and Responsiveness:

Mechanical systems often lacked the precision and responsiveness needed for fine-tuning plant operations, leading to inefficiencies and slower reaction times to changing conditions.

Complexity and Maintenance:

The mechanical nature of these systems made them complex and prone to wear and tear, requiring frequent maintenance and skilled technicians for repairs, which could increase operational costs and downtime.

SOURCE:

<https://www.electricalindia.in/a-brief-history-of-automation-of-electricity-generation/>

S. JNANESWAR
22VV1A0258
III B.TECH EEE

WIRELESS POWER THEFT MONITORING

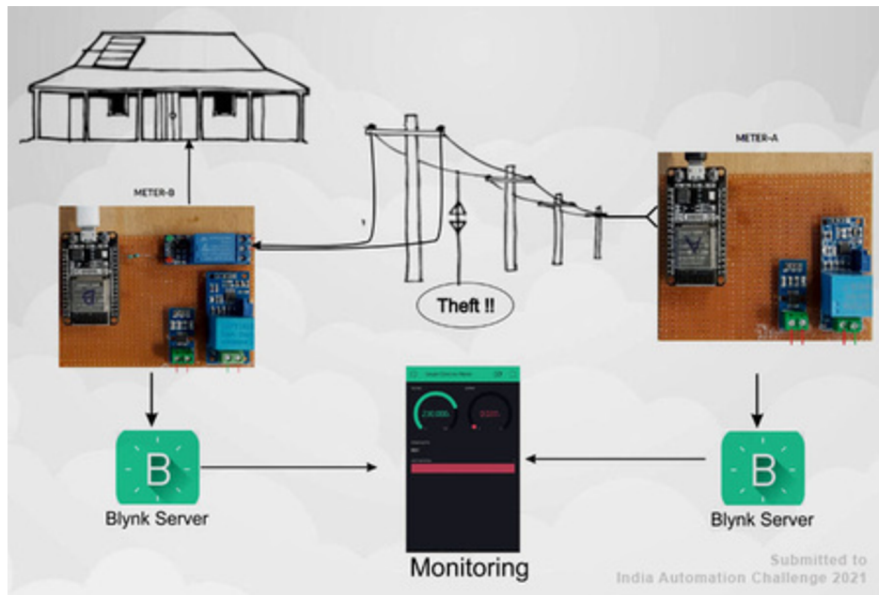

The main aim of power theft monitoring and indication system at local substation using wireless technology indicates the location where the power is being stolen. The main purpose of power theft monitoring is saving the power that is being gone worthless.

Power theft is one of the biggest problems which causes huge power loss to electricity boards and to compensate this, the cost per unit is increased. If we keep an eye check on these power thefts, we save lot of power by tracking the electricity used. This will ultimately reduce household power bills.

Theft of Power:

These are the losses caused intentionally by humans by illegal access to the power distribution networks. the Electricity theft is termed as non technical loss. technical losses can be reduced substantially. However to reduce commercial losses, strategic approach is essential. This reduce the losses. Due to technology development, electricity theft is estimated to result in huge amount of revenue loss per year in India.

Methods to reduce Power Theft:

Energy meter tampering: The meter can be detected by using a simple arrangement of IR LED and a Photodiode. It in used in places where conventional Electromechanical energy meters are used.

The way of Power Theft: 1. **Power Taping:** Often power theft is done during transmission by illegal tapping of the power lines to divert the power to the required destinations. It is also done by illegal connections to the power grid stations which are cut at the time of billing. 2. **Meter Fraud:** IN many areas where the manual meter reading is done, the person is always bribed to give false readings and thus the amount paid is for lesser amount of power compared to the power actually consumed.

Power tampering can be detected by comparing the power distributed to the line and the power actually consumed by the load. This can be done by installing an Electronic energy meter at the load side and the meter readings are sent wirelessly to

SOURCES:

<https://www.allaboutcircuits.com>
<https://www.elprocus.com>
<https://www.academia.edu>

M. VASANTHA
22VV1A0234
III B.TECH EEE

SEMICONDUCTOR CHIPS

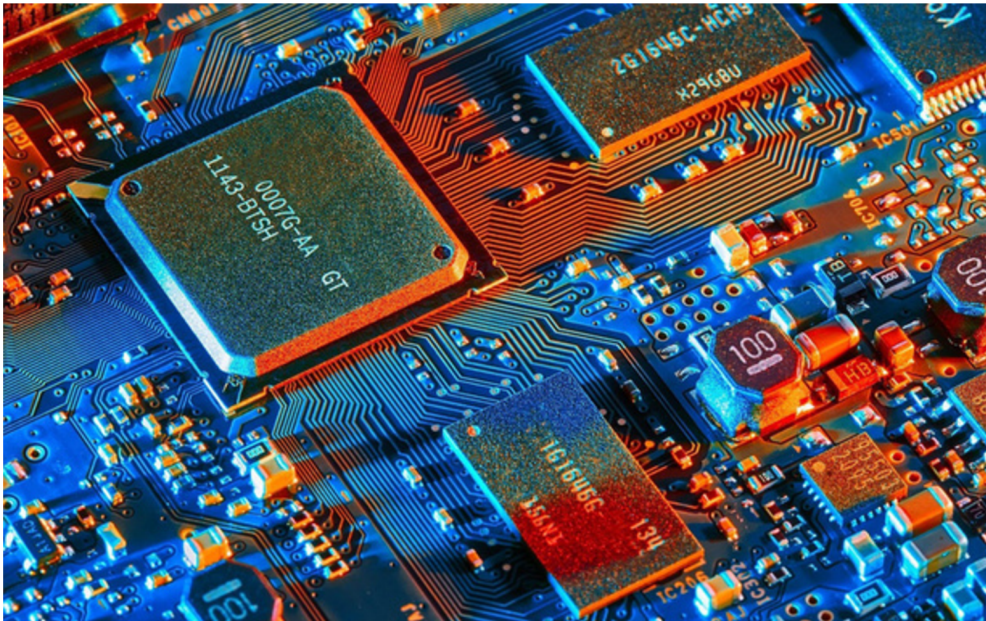

Semiconductor chips are brain of the electronic device. In world everyday 100 billions of SC chips are needed. now a days technology increase rapidly demanding more every gadget need semiconductors chips. SC are used manufacturing of phone, television, cars etc. in Most semiconductor chip manufacture companies in Taiwan, China, Hong Kong, Japan, USA etc. Silicon represents almost 25% of material used in manufacturing of smartphones. Mainly in cars used to control everything from emissions system to driver assist system.

Why Semiconductor chips are important?

Semiconductor crisis is the most critical economic threat in world. Apple company loss \$6billion loss due to shortage of SC chips. Maruti company 1.16lakhs vehicles are not produce because of shortage of SC chips .

Why are SC chips going scarce?

Manufacturing of SC is difficult process and three months time taken for end product. COVID pandemic has had a huge impact on manufacturing of SC chips. Due to the advancement of technology, the SC chips are going out of stock as they take more time to manufacture.

Semiconductor chips hub:

At present, Taiwan produces 60% chips across the world.

How is India going to dominate the semiconductor chip market?

India has moved forward to eliminate depending on China and Taiwan. It has encouraged investors in manufacturing SC companies in the country itself. Due to rapid increment of demand for semiconductor chips, India is seen as a global semiconductor manufacturing unit in the nearby time. Also, it has invited companies like Foxconn and Micron to set up 20 manufacturing centers in India in the next two years.

The future of semiconductors continues to evolve, and current trends foreshadow even higher levels of innovation and competition. Prior to 2023, increased demand, geopolitical conflicts, closed factories, and inflation had led to semiconductor shortage and a dip in production

Manufacturers are increasing chip production - but the shortfall won't be resolved immediately. Despite the current problems, the industry remains highly profitable. When chip shortages first shut down automotive production lines in 2021, the semiconductor industry found itself in an unaccustomed spotlight.

SOURCE:

<https://www.howtogeek.com/737644/what-is-a-semiconductor/>

K.DIVYA APARNA
22VV1A0229
III B.TECH EEE

NEURALINK

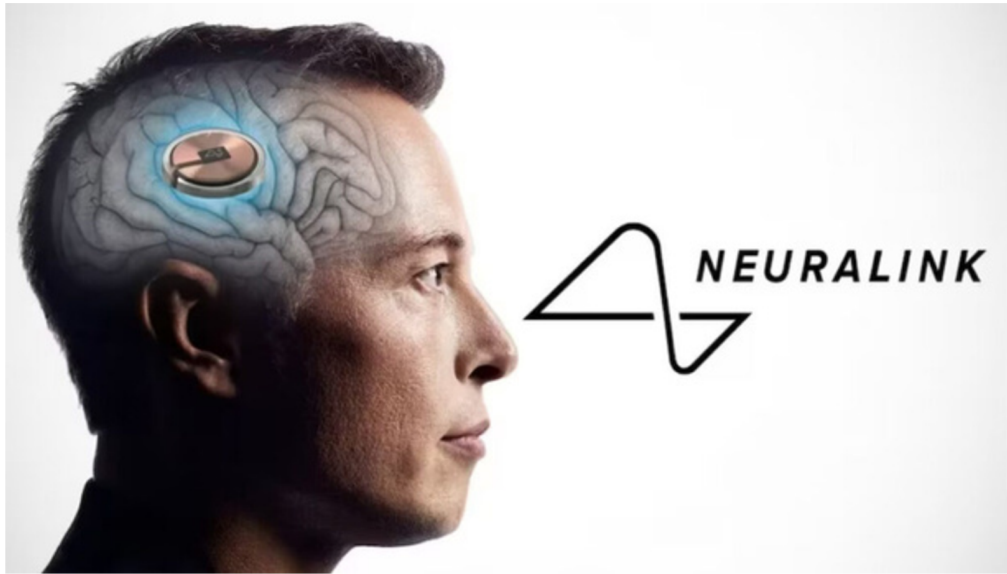

Neuralink Corp is an American neurotechnology company that has developed, as of 2024, implantable brain-computer interfaces (BCIs). It was founded by Elon Musk and a team of seven scientists and engineers (Max Hodak, Benjamin Rapoport, Dongjin Seo, Paul Merolla, Philip Sabes, Tim Gardner, Tim Hanson, and Vanessa Tolosa). Neuralink was launched in 2016 and was first publicly reported in March 2017. The company is based in Fremont, California with plans to build a three-story building with office and manufacturing space near Austin, Texas in Del Valle, located about 10 miles east of Tesla's headquarters and manufacturing plant that opened in 2022.

The company has faced criticism for a large amount of euthanization of primates that underwent medical trials. Veterinary records of the monkeys showed a number of complications with electrodes being surgically implanted. On January 29, 2024, Musk announced that Neuralink had successfully implanted a Neuralink device in a human and that the patient was recovering.

The company has faced criticism for a large amount of euthanization of primates that underwent medical trials. Veterinary records of the monkeys showed a number of complications with electrodes being surgically implanted. On January 29, 2024, Musk announced that Neuralink had successfully implanted a Neuralink device in a human and that the patient was recovering.

Since its founding, the company has hired several high-profile **neuroscientists** from various universities. By July 2019, it had received \$158 million in funding (of which \$100 million was from Musk) and was employing a staff of 90 employees. At that time, Neuralink announced that it was working on a "sewing machine-like" device capable of implanting very thin (4 to 6 μm in width) threads into the brain, and demonstrated a system that reads information from a lab rat via 1,500 electrodes. They had anticipated starting experiments with humans in 2020, but have since moved that projection to 2023. As of May 2023, they have been approved for human trials in the United States.

HISTORY

Neuralink was founded in 2016 by Elon Musk and a founding team of seven scientists and engineers (Max Hodak, Benjamin Rapoport, Dongjin Seo, Paul Merolla, Philip Sabes, Tim Gardner, Tim Hanson, and Vanessa Tolosa). The group of initial hires consisted of experts in areas such as neuroscience, biochemistry and robotics. The trademark "Neuralink" was purchased from its previous owners in January 2017.

In April 2017, Neuralink announced that it was aiming to make devices to treat serious brain diseases in the short-term, with the eventual goal of human enhancement, sometimes called transhumanism. Musk had said his interest in the idea partly stemmed from the science fiction concept of "neural lace" in the fictional universe in *The Culture*, a series of 10 novels by Iain M. Banks.

SOURCE:

<https://en.wikipedia.org/wiki/Neuralink>

G. PAVAN
22VV1A0223
III B.TECH EEE

How Do All-Electric Cars Work?

All-Electric Vehicle

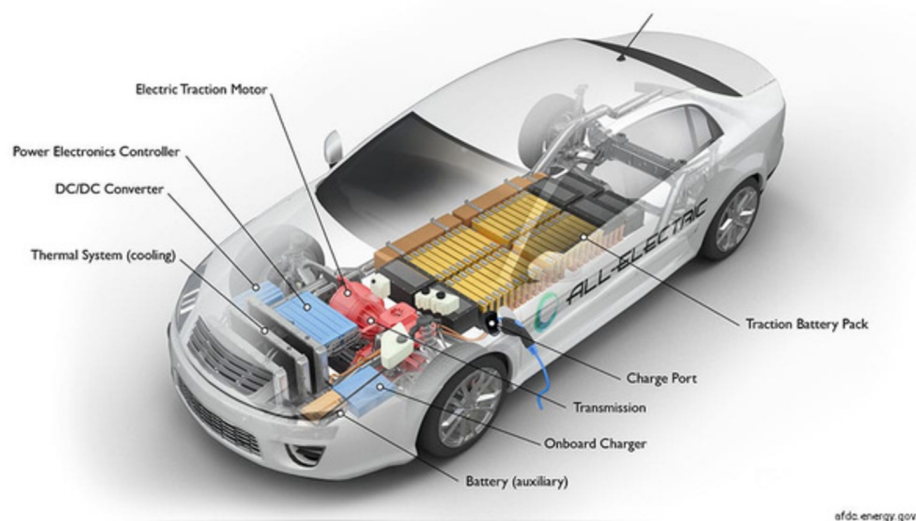

All-electric vehicles, also referred to as battery electric vehicles (BEVs), have an electric motor instead of an internal combustion engine. The vehicle uses a large traction battery pack to power the electric motor and must be plugged in to a wall outlet or charging equipment, also called electric vehicle supply equipment (EVSE). Because it runs on electricity, the vehicle emits no exhaust from a tailpipe and does not contain the typical liquid fuel components, such as a fuel pump, fuel line, or fuel tank. Learn more about electric vehicles.

Key Components of an All-Electric Car

Battery (all-electric auxiliary): In an electric drive vehicle, the auxiliary battery provides electricity to power vehicle accessories.

Charge port: The charge port allows the vehicle to connect to an external power supply in order to charge the traction battery pack.

DC/DC Converter: This device converts higher-voltage DC power from the traction battery pack to the lower-voltage DC power needed to run vehicle accessories and recharge the auxiliary battery.

Electric traction motor: Using power from the traction battery pack, this motor drives the vehicle's wheels. Some vehicles use motor generators that perform both the drive and regeneration functions.

Onboard charger: Takes the incoming AC electricity supplied via the charge port and converts it to DC power for charging the traction battery. It also communicates with the charging equipment and monitors battery characteristics such as voltage, current, temperature, and state of charge while charging the pack.

Power electronics controller: This unit manages the flow of electrical energy delivered by the traction battery, controlling the speed of the electric traction motor and the torque it produces. **Thermal system (cooling):** This system maintains a proper operating temperature range of the engine, electric motor, power electronics, and other components.

Traction battery pack: Stores electricity for use by the electric traction motor. **Transmission (electric):** The transmission transfers mechanical power from the electric traction motor to drive the wheels.

Transmission (electric): The transmission transfers mechanical power from the electric traction motor to drive the wheels.

SOURCE:

<https://afdc.energy.gov/vehicles/how-do-all-electric-cars-work>

CH DILEEP
22VV1A0213
III B.TECH EEE

ELECTRIC VEHICLES

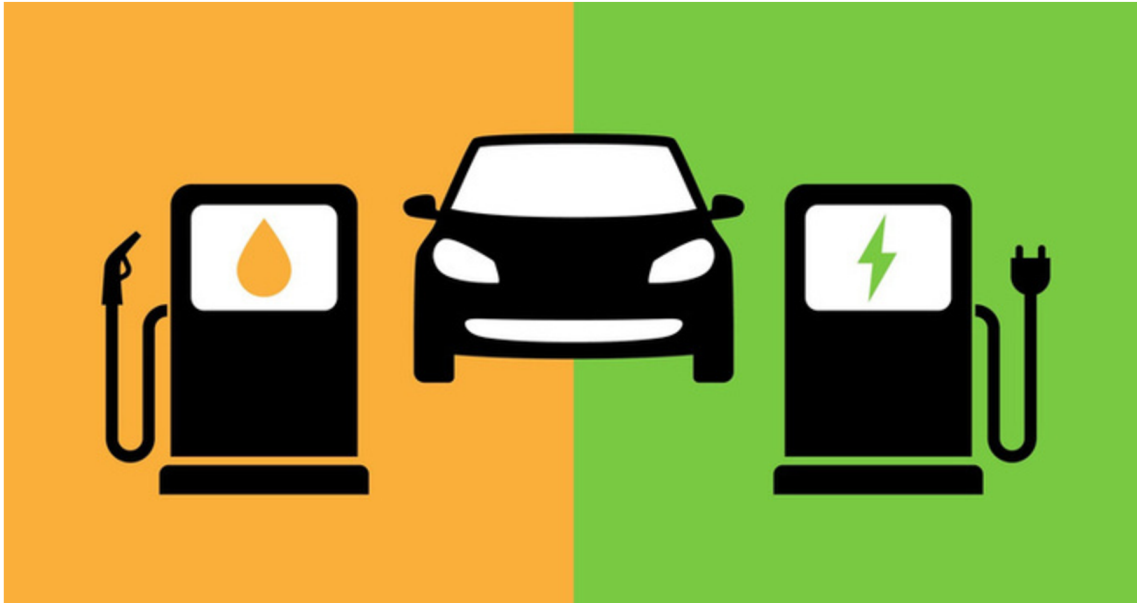

An Electric Vehicle is a vehicle that uses one or more electric motors for propulsion. It can be powered by an collector system, with electricity from extra vehicle sources or it can be powered autonomously by a battery. EVs are not only limited to road and rail vehicles, and broadly can also include electric boat and underwater vessels, electric aircraft and electric spacecraft.

Electric Vehicles (EVs) have emerged as a transformative source in the automotive industry, promising a sustainable future for transformation. These are powered by electricity, either from grid connected sources or on board batteries.

Benefits of Electric Vehicles:

1. First and foremost, EVs offer a substantial reduction of greenhouse gases' emission. They produce zero tailpipe emissions. This is a significant step towards combating climate change and improving air quality in urban areas.
2. On the other hand, EVs provide higher energy efficiency. Electric motors are more efficient than IC engines, converting higher percentage of energy from grid into vehicle movement.

But on the other side, there are some challenges such as the need for wide spread charging infrastructure and addressing the environmental impact of battery production and disposal. Nevertheless, with ongoing advancements in technology and growing environmental awareness, EVs are poised to play a central role in the transition to a more sustainable and eco friendly transportation system. EVs often benefit from government incentives such as tax credits and rebates, which make them even more appealing to buyers. There are some challenges to EV adoption. Range anxiety or the fear of running out of battery power remains a concern for consumers. While battery technology continues to improve, expanding charging infrastructure is crucial to address the charging stations. It's essential for governments, industry players and consumers to continue supporting and investing in EVs technology to accelerate the transition. Government incentives to increase adoption were first introduced in the late 2000s, including in the US and the EU, leading to the growing market for vehicles in the 2010s. Increasing public interest, awareness and structural incentives such as those being built into the green recovery from the pandemic, are expected to greatly increase the EV market. International Energy Agency has stated that governments should do more to meet climate goals , including policies for heavy electric vehicles.

SOURCE:

<https://www.techradar.com/news/evs-explained>

P. LAVANYA
22VV1A0246
III B.TECH EEE

CHANDRAYAAN 3



Chandrayaan-3 is the third mission in the Chandrayaan programme, a series of lunar-exploration missions developed by the Indian Space Research Organisation (ISRO). The mission consists of a Vikram lunar lander and a Pragyan lunar rover was launched from Satish Dhawan Space Centre on 14 July 2023. The spacecraft entered lunar orbit on 5 August, and India became the first country to touch down near the lunar south pole, at 69°S, the southernmost lunar landing on 23 August 2023 at 18:03 IST (12:33 UTC), made ISRO the fourth space agency to successfully land on the Moon, after USSR, NASA and the CNSA.

Chandrayaan-3 was launched from Satish Dhawan Space Centre on 14 July 2023. The spacecraft entered lunar orbit on 5 August, and became the first lander to touch down near the lunar south pole on 23 August at 18:03 IST (12:33 UTC), making India the fourth country to successfully land on the Moon, and at 69°S, the southernmost lunar landing, until IM-1 landed further southwards in Malapert A crater on 22 February 2024. The lander was not built to withstand the cold temperatures of the lunar night, and sunset over the landing site ended the surface mission twelve days after landing.

History:

On 22 July 2019, ISRO launched Chandrayaan-2 on board a Launch Vehicle Mark-3 (LVM3) launch vehicle consisting of an orbiter, a lander and a rover. The lander was scheduled to touch down on the lunar surface on 6 September 2019 to deploy the Pragyan rover. The lander lost contact with mission control, deviated from its intended trajectory while attempting to land near the lunar south pole, and crashed.

The lunar south pole region holds particular interest for scientific exploration. Studies show large amounts of ice there. The ice could contain solid-state compounds that would normally melt under warmer conditions elsewhere on the Moon—compounds which could provide insight into lunar, Earth, and Solar System history. Mountains and craters create unpredictable lighting that protect the ice from melting, but they also make landing there a challenging undertaking for scientific probes. For future crewed missions and outposts, the ice could also be a source of oxygen, of drinking water as well as of fuel due to its hydrogen content.

The European Space Tracking network (ESTRACK), operated by the European Space Agency (ESA), and Deep Space Network operated by Jet Propulsion Laboratory (JPL) of NASA are supporting the mission. Under a new cross-support arrangement, ESA tracking support could be provided for upcoming ISRO missions such as those of India's first human spaceflight programme, Gaganyaan, and the Aditya-L1 solar research mission. In return, future ESA missions will receive similar support from ISRO's own tracking stations.

For the first time on the lunar surface, a laser beam from NASA's Lunar Reconnaissance Orbiter was broadcast on 12 December 2023, and it was reflected back by a tiny NASA retroreflector on board the Vikram lander. The purpose of the experiment was to determine the retroreflector's surface location from the moon's orbit. The Chandrayaan-3 lander's Laser Retroreflector Array (LRA) instrument began acting as a location marker close to the lunar south pole.

SOURCE:

<https://en.wikipedia.org/wiki/Chandrayaan-3>

SK. KHADHAR GULAM
22VV1A0257
III B.TECH EEE

STUDENT ACTIVITIES

A STUDENT CLUB



CLIQUE

- A PLACE TO GET INVOLVED

Clique is a student club of EEE department which started in 2023 with an objective to bring the hidden qualities out. The events conducted on weekends demonstrate active participation and competitive spirit.

Clique aims to develop qualities of confidence and self learning process in one's mind. Through various workshops, seminars, and competitions, Clique encourages students to explore their interests and hone their skills. Members have the opportunity to engage in hands-on projects that not only enhance their technical abilities but also foster teamwork and collaboration.

By bringing together diverse talents, Clique creates an environment where students can learn from one another, share ideas, and inspire each other to reach their full potential.

In addition to technical workshops, Clique organizes guest lectures from industry professionals, providing insights into real-world applications of electrical and electronic engineering. These interactions bridge the gap between academia and industry, preparing members for their future careers. The club also emphasizes the importance of leadership and communication skills, offering training sessions that equip students to present their ideas effectively and confidently.

Moreover, Clique is committed to community service, organizing outreach programs that allow members to apply their skills for the benefit of society. This not only reinforces their learning but also instills a sense of responsibility and social

POSTER PRESENTATION

T. Vijay Kumar and B. Supriya of 3rd BTech EEE JNTU-GV have organized this poster presentation event on 21st September 2023.

This Event is organized with the Objective to encourage the innovative ideas of students. The Main Moto of this Club Clique, is to Get Involved in all the Aspects.

Number of participants: 23 batches



BRAIN TEASER

Sk.Khadhar Gulam and S. Swathi of 3rd BTech EEE JNTU-GV have organized this Brain Teaser on 17th February 2024.

This Event is Organised with the Objective to encourage the innovative ideas of students. The Main Moto of this Club Clique, is to Get Involved in all the Aspects.

Number of participants: 55



GUESS THE COMPONENTS

P. Tharun and M. Revathi of 3rd BTech EEE JNTU- GV have organized the guess the components event on 16th March 2024.

This Event is Organised with the Objective to encourage the innovative ideas of students. The Main Moto of this Club Clique, is to Get Involved in all the Aspects.

Number of participants: 35



PUZZEL FOZZY

K.Adarsh and K.Gayathri of 3rd BTech EEE JNTU-GV have helded the Puzzel Fozzy event on 23rd March 2024.

This Event is Organised of the event is to improve the analytical thinkingskills and to improve the focus and attention span and to maintain team spirit. The Main Moto of this Club Clique is to Get Involved in All the Aspects.

Number of participants: 56



FOOD DONATION

The students of 3rd BTech EEE at JNTU-GV organized a Food Donation event on April 3, 2024.

One of the most important advantages of providing food to those in need is fostering a sense of community. The primary goal of the event is to express support, love, and connection. Consider how food has the power to unite individuals. The core motto of this Club Clique is to actively engage in every aspect.

Number of participants: 67

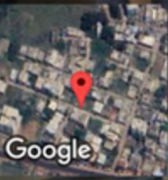

Vizianagaram, Andhra Pradesh, India
PLOT NO-54B, Sai Baba Nagar, Vizianagaram Cantonment, Vizianagaram, Andhra Pradesh 535003, India
Lat 18.120602°
Long 83.383522°
03/04/24 03:54 PM GMT +05:30

GPS Map Camera

COORDINATORS

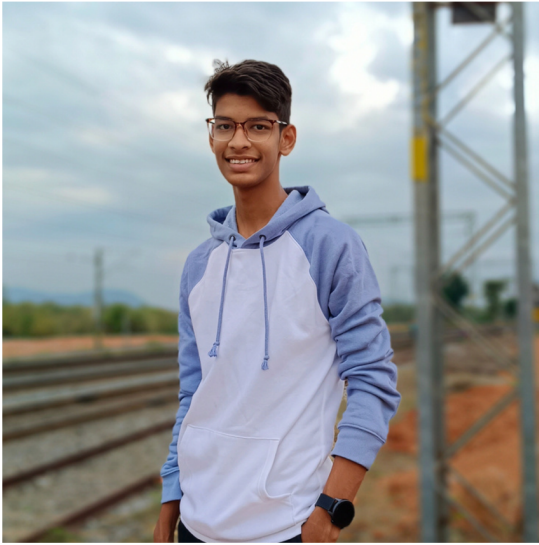

TEJA DURGA SURAJ G
22VVIA0259



MARISA VASANTHA
22VVIA0234

We are excited about the possibilities that lie ahead and are committed to pushing the boundaries of creativity and collaboration. The success of our recent events has not only strengthened our bond as a team but has also inspired us to explore new ideas and initiatives that can benefit our community.

As we plan for the future, we invite all members to share their thoughts and suggestions on how we can enhance our programs and make an even greater impact. Your insights are invaluable, and together, we can create experiences that resonate deeply with participants and foster a spirit of engagement and learning.

- Thank You

TEJA DURGA SURAJ. G
M. VASANTHA

LITERARY NODE

As part of our department's efforts to promote academic excellence and provide resources to our students, we have identified and sponsored some students to support the development of our department library.

Objective:

The objective of this sponsorship is to encourage students to utilize the library resources, develop research skills, and contribute to the growth of the department's knowledge base.



VIVEK SIKINAM



RAM GOPAL GUTHULA



VAKANI PARDHA SARADHI



ORUGANTI ANJAN KUMAR

Several others also supported books and established themselves in strong positions, including **PUNYAMANTHULA SANTHOSH PUSHPA ANAND KUMAR, KOLLI VARA PRASAD** and Others.

BOOKS SPONSORED BY EEE STUDENTS

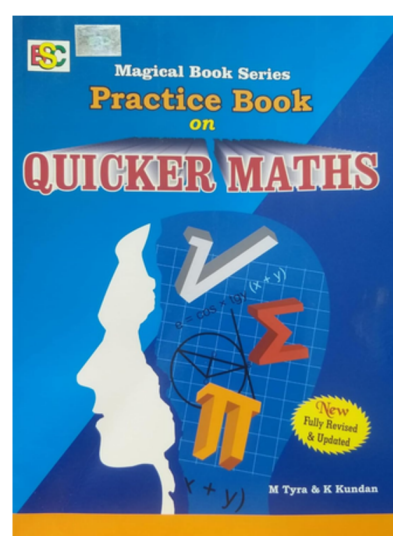
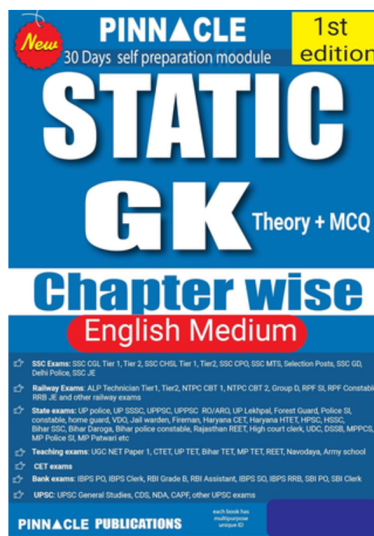
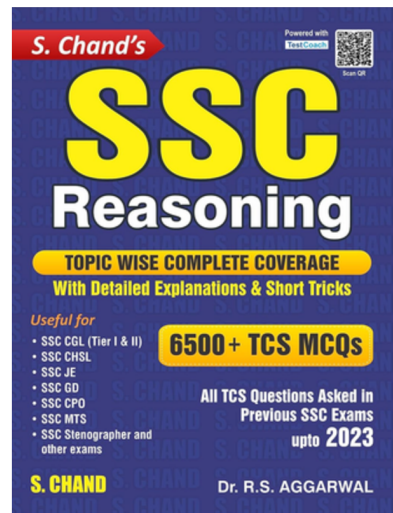
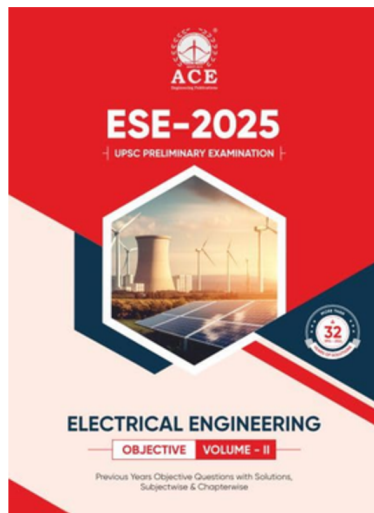
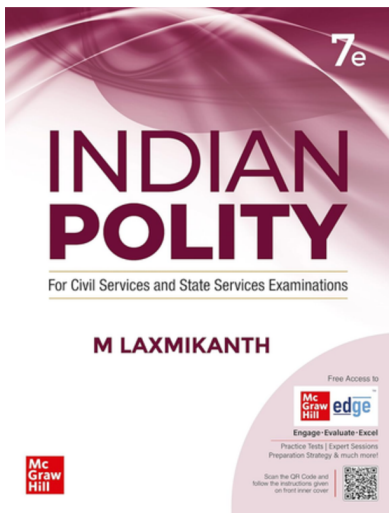
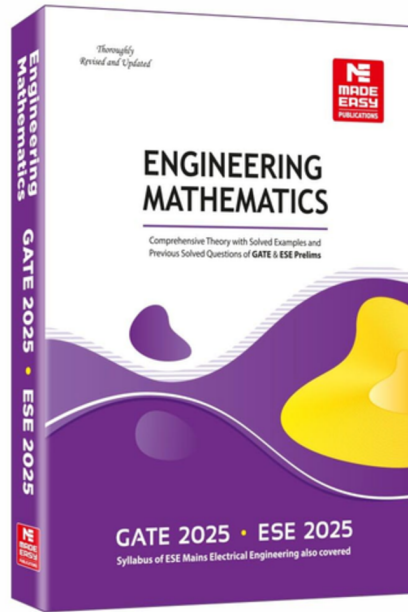

Conclusion:

We believe that this sponsorship will not only benefit the selected students but also enhance the overall academic environment of our department. We look forward to seeing the positive impact of this initiative.



"MANY OF LIFE'S FAILURES ARE PEOPLE WHO DID NOT REALIZE HOW CLOSE THEY WERE TO SUCCESS WHEN THEY GAVE UP."

-THOMAS ALVA EDISON

"IF YOUR HATE COULD BE TURNED INTO ELECTRICITY, IT WOULD LIGHT UP THE WHOLE WORLD."

-NIKOLA TESLA

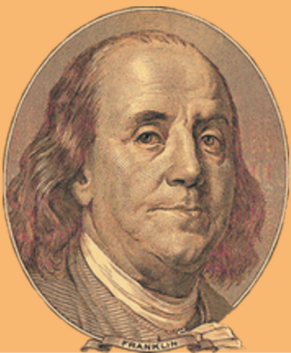
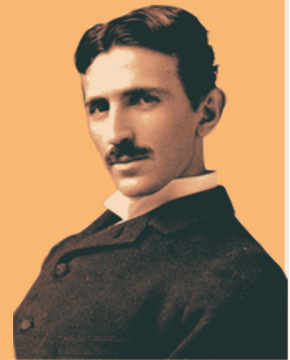

"WITHOUT CONTINUAL GROWTH AND PROGRESS, SUCH WORDS AS IMPROVEMENT, ACHIEVEMENT AND SUCCESS HAVE NO MEANING,"

-BENJAMIN FRANKLIN

"CONCENTRATE ALL YOUR THOUGHTS UPON THE WORK AT HAND. THE SUN'S RAYS DO NOT BURN UNTIL BROUGHT TO A FOCUS."

-ALEXANDER GRAHAM BELL



VOLUME XII
SEPTEMBER-2024